

UNIVERSAL/MULTIFLEX

INTERNATIONAL

Factory Parts Catalog

Product No.	MET1041ZAS3
Market	Export
Color	white
Volts	230 - 50/60 Hz
Wiring Diagram	134724400
Owner's Guide	131957200
Installation Instructions	131457000
Operating Instructions	134089600
Operating Instructions	131921300

INTERNATIONAL
3 Parkway Center, Pittsburgh, PA 15220

Publication No.
5995483194
07/01/29
(EN/SERVICE/WC)
361

LAUNDRY CENTER WITH ELECTRIC DRYER

Model No.
MET1041ZA

Copyright © 2007 Electrolux Home Products, Inc.
All rights reserved.

UPPER CABINET/DRUM HEATER

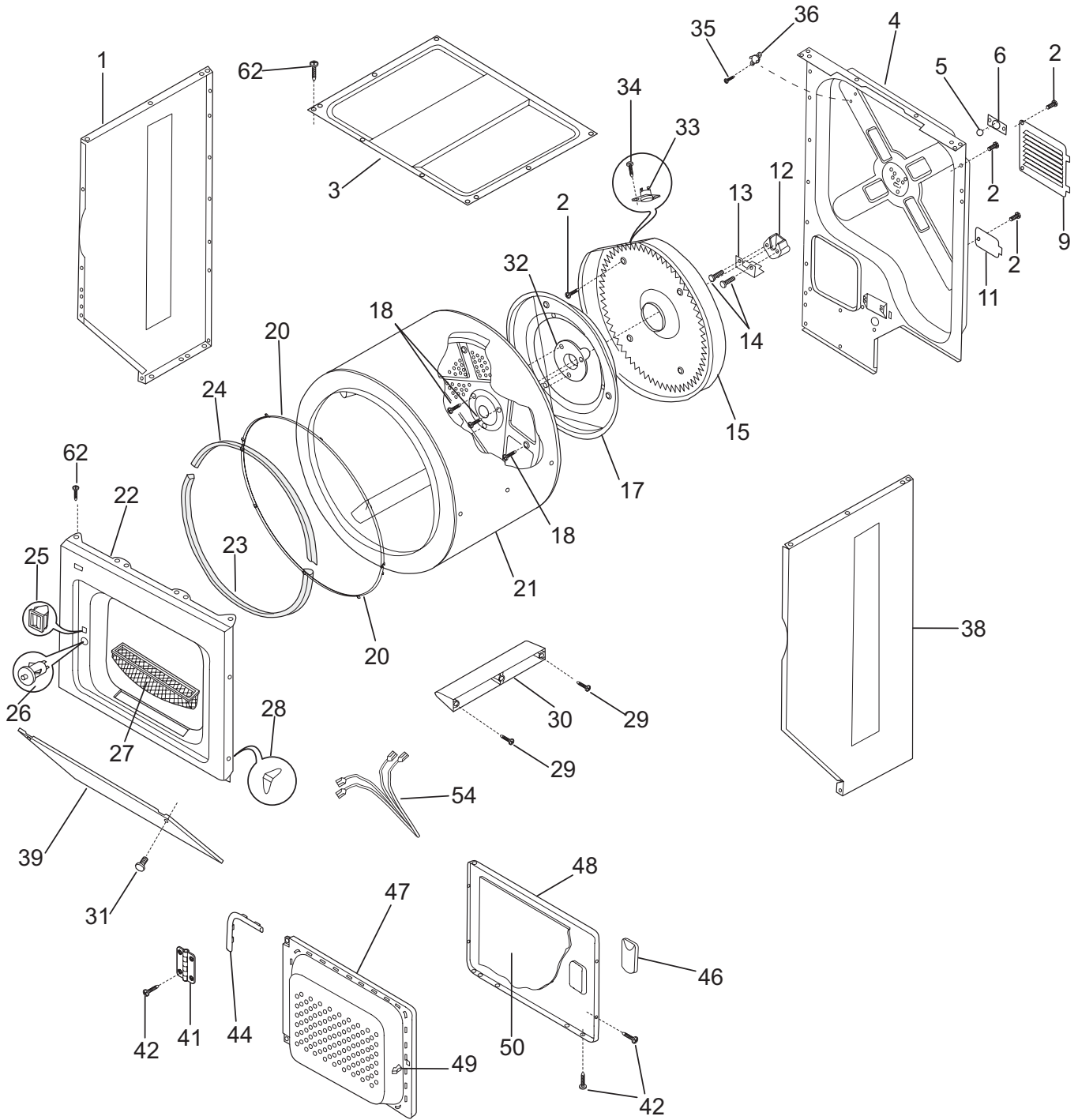

P17U0051

UPPER CABINET/DRUM HEATER

POS. NO	PART NO.	DESCRIPTION
1	131084710	Panel, white, left side
2	131168200	Screw, pan head, 8-18B x 0.31
3	131883301	Panel, top
4	134799902	Panel, rear, steel, galvanized
5	5303281019	Ball, grounding
6	5303281020	Clip, ball, steel, flat nut
9	3204249	Panel, motor access, rear
11	3204250	Cover, terminal block
12	131825900	Bearing, drum support
13	131724300	Bracket, bearing support
14	131205400	Screw, bracket mtg., 10-16B x 1.375, cr/sq drive
15 #	131475300	Heater Assy, w/housing
17	3204254	Baffle, heater shield
18	131477000	Screw, 10-16AB x 0.375
20	131963900	Glide, drum
21	134122572	Drum, dryer, painted, service kit
22	131636237	Panel, front, white
22*	131870700	Plug, light hole
23	134134700	Seal, felt, lower
24	134036400	Seal, felt, upper
25	131658800	Door Catch
26 #	131843100	Switch, door
27	131359600	Lint Trap
28	134440000	Clip, guide
29	131382300	Screw, quadrex head, 10-14 x 1.00, vane mtg., special
30	5303201200	Vane, straight
31	131202300	Screw, 10-16AB x 0.625
32	131777700	Shaft, drum support, ballhitch
33 #	3204267	Thermostat, safety
34	131243800	Screw, pan hd locking, 8-32CA x 0.375, cup point
35	131892100	Screw, 6-20B x 0.230
36 #	134120900	Thermal Limiter
38	131084810	Panel, white, right side
39	131084402	Panel, access, white, front
41	134222900	Hinge, dryer door
42	134156200	Screw, flat head, 8-18AB x 0.44, quad drive
44	131129900	Gasket, door seal
46	131789400	Handle, door, white
47	131579103	Panel, inner door, white
48	131789303	Panel, outer door, white
49	5303211430	Door Strike
50	134535300	Insulator, heat shield, outer door
54 #	134846300	Wiring Harness, door switch
62	131258400	Screw, 10-16AB x 0.500

MOTOR/BLOWER/BELT

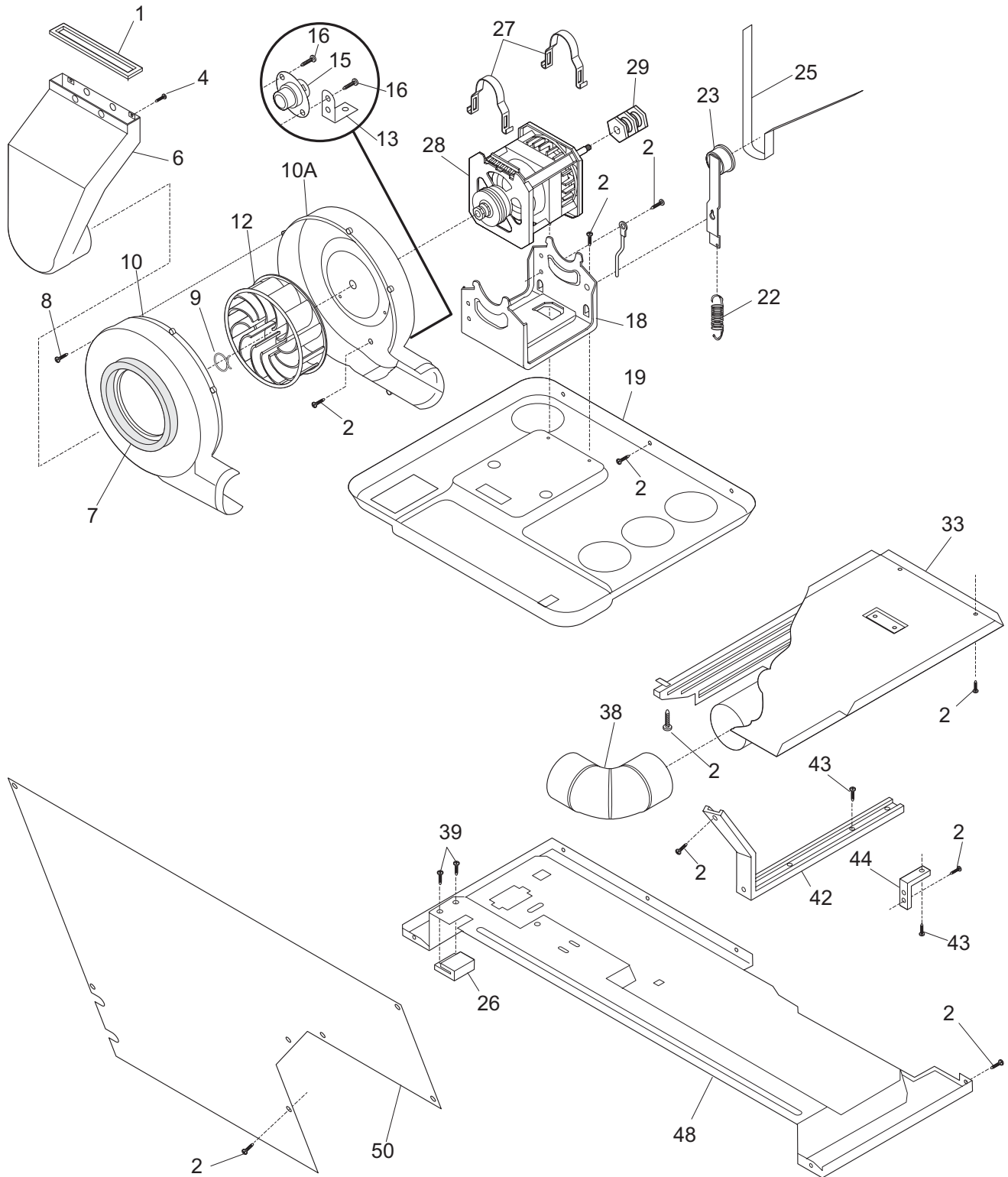

P17B0053

MOTOR/BLOWER/BELT

POS. NO	PART NO.	DESCRIPTION
1	131295200	Seal, air duct
2	131168200	Screw, pan head, 8-18B x 0.31
4	131362400	Fastener, push-in
6	134086300	Duct, air
7	3204490	Seal, housing, to air duct
8	3205245	Screw, pan head, 6-18AB x 0.60
9	5303304824	Clamp
10	134611700	Housing, blower, front, with seal
10A	134608200	Housing, blower, rear
12 #	131665000	Blower Wheel
13	134608400	Ground Strap, thermostat
15 #	131298300	Thermostat, temp control
16	131243700	Screw, pan head, 8-18AB x 0.375
18	131413600	Cradle, motor mount, with idler stud
19	134613501	Panel, motor cradle mt, upper
22	3205241	Spring, idler
23	131863100	Idler Arm Assy, with pulley
25 #	134503900	Belt, dryer drive
26	5303212870	Block, support, bottom panel
27	134242400	Clamp, motor mtg.
28 #	134196700	Motor, dryer drive, with pulley
29 #	131294400	Pulley, motor, back shaft, 50/60 Hz cvrsn
33	131731400	Shield, access area, cover
38	3204320	Elbow, exhaust duct
39	131205100	Screw, #8 pan head, 10-10B x 0.500, cr/sq drive
42	5304439185	Bracket, marriage, interior
43	131751500	Screw, hex head, 12-24T 0.63
44	3204326	Bracket, L mounting, cabinet rear, external
48	131731310	Panel, dryer, bottom rear
50	3204329	Cover, safety, lower front

CONTROL PANEL

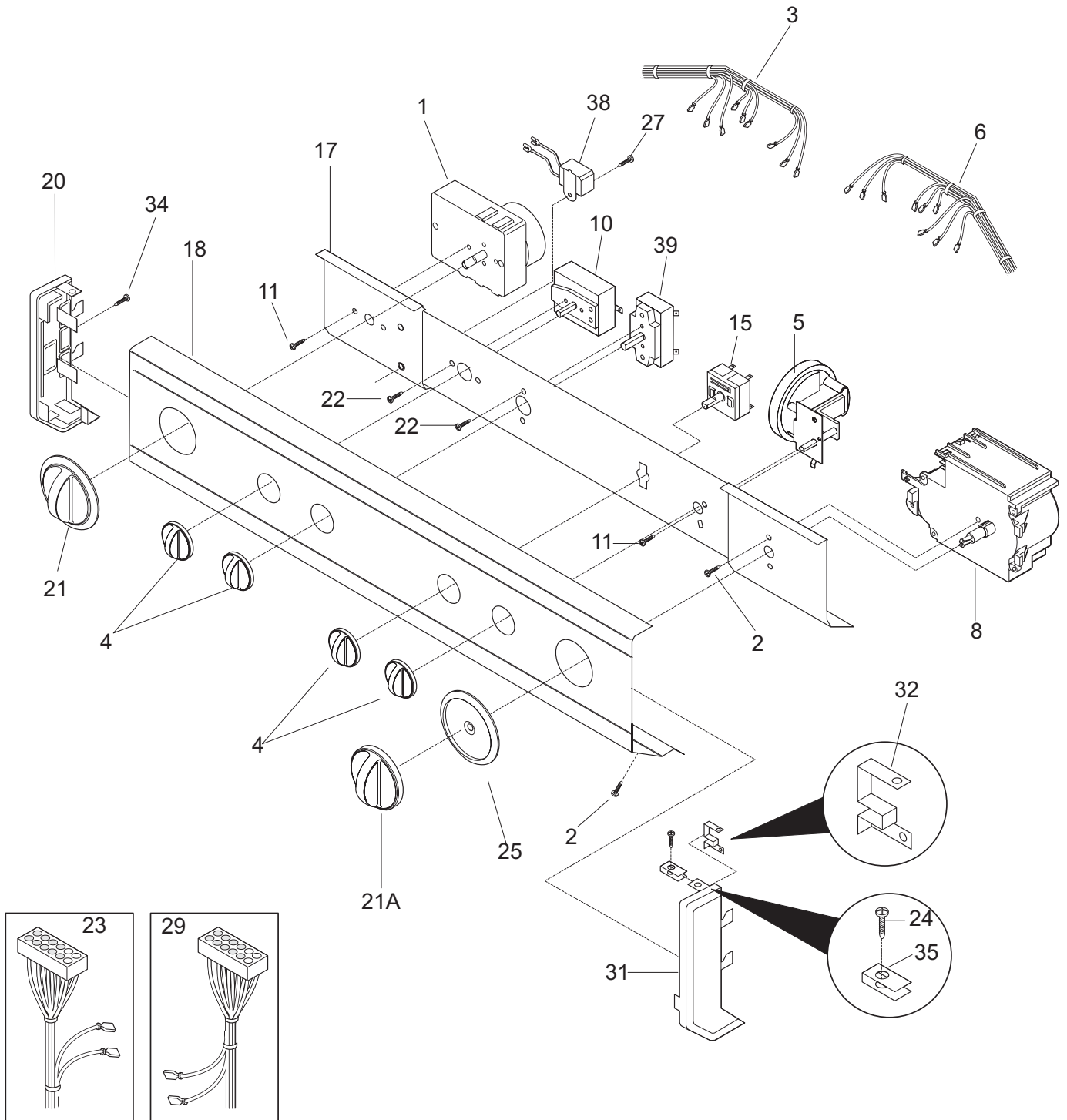

P17C0085

CONTROL PANEL

POS. NO	PART NO.	DESCRIPTION
1 #	131583802	Timer, dryer
2	131168200	Screw, pan head, 8-18B x 0.31
3 #	134095400	Wiring Harness, dryer control
4	131873404	Knob, rotary, white/dk gray
5	134500000	Switch, pressure, 3 position, 3/4 hp
6 #	134542500	Wiring Harness, washer control, w/temp switch
8 #	134049601	Timer, washer, 4-off
10 #	134399700	Switch, start, LCD
11	5303283289	Screw, cr pan head, 8-32 x 0.250, thread forming
15 #	134192400	Switch, water temp, 4 posn rotary
17	134263400	Bracket, control mount
18	134093300	Panel, trimplate, console front
18*	131535101	Bezel, nameplate, white
20	131288101	End Cap, white, LH
21	131873304	Knob, dryer timer, white
21A	131977201	Knob, washer timer, white
22	3161259	Screw, switch mtg, 6-32 x 0.19, (2), sems
23 #	134605600	Wiring Harness, main
24	134156200	Screw, flat head, 8-18AB x 0.44, quad drive
25	131976804	Indicator, timer pointer, white/dark gray, washer
27	131892100	Screw, 6-20B x 0.230
29 #	134689500	Wiring Harness, washer, lower
31	131288211	End Cap, white, RH
32	3204357	Clip, grounding
34	131243700	Screw, pan head, 8-18AB x 0.375
35	5308014350	Clip, end cap mtg, U-type
38 #	131294600	Buzzer
39 #	134399800	Switch, dryer temp, rotary 4 pos

LOWER CABINET/TOP

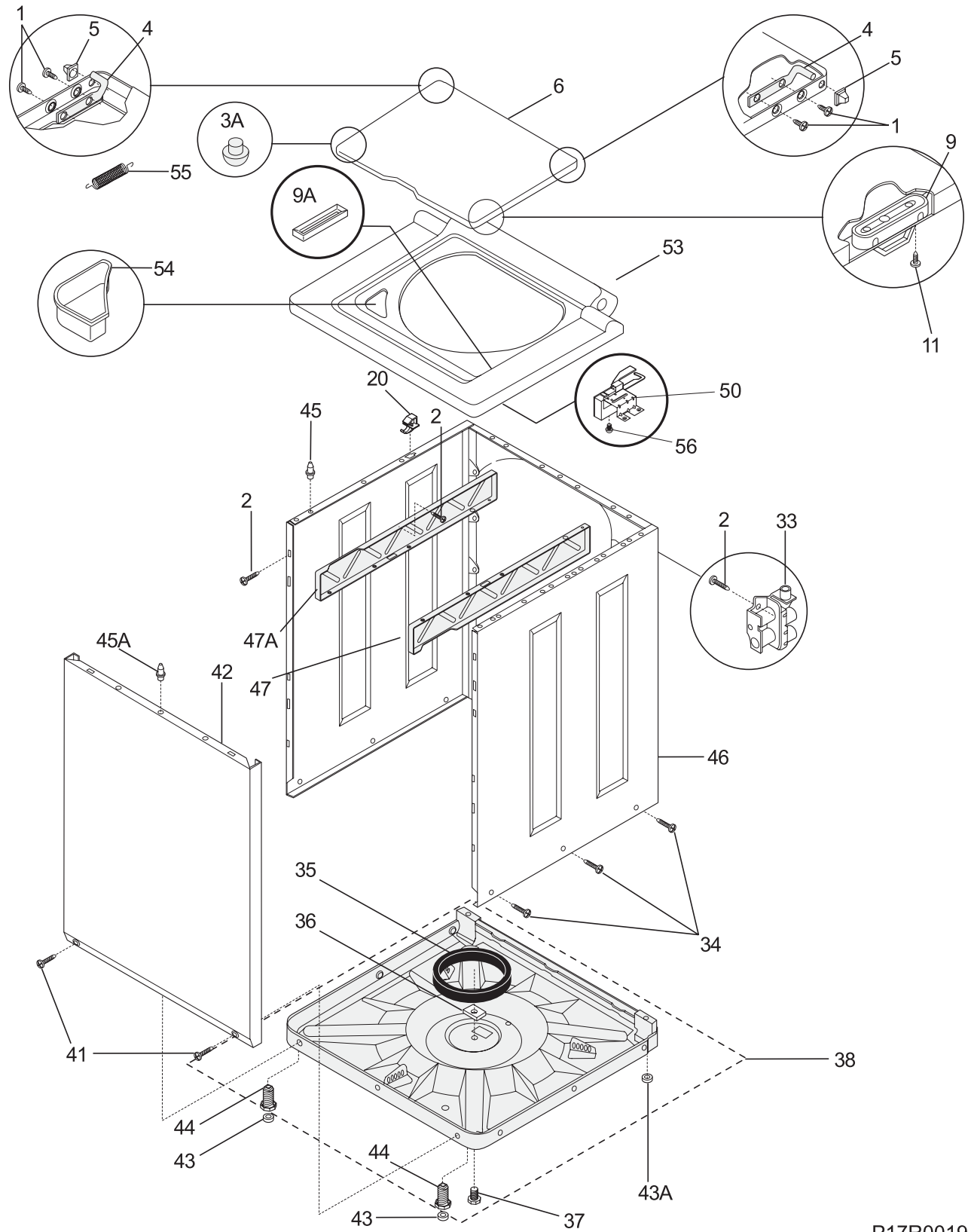

P17R0019

LOWER CABINET/TOP

POS. NO	PART NO.	DESCRIPTION
1	134203900	Screw, pan hd phillips, 6-32 x 0.337, dog point
2	131168200	Screw, pan head, 8-18B x 0.31
3A	134075500	Bumper, lid, front
4	3205250	Hinge Bar
5	5303208743	Grommet, hinge
6	5303212872	Lid, washer, white
9	131390000	Lid Strike
9A	134768500	Insert, striker plate, lid slot
11	3204368	Screw, lid strike mtg, 6-20B X 0.375
20	3204374	Pin, slide, side to top
33 #	131461300	Valve, water, 230 V, low pressure
34	131205500	Screw, cab body, 1/4-14 x 0.625, side-to-base
35	5308002385	Snubber Ring
36	3204380	Shipping Block
37	131658900	Screw, shipping, 1/4-20 x 1.001, yellow, unit base, thread forming
38	5303311213	Base Assembly
41	131258400	Screw, 10-16AB x 0.500
42	131104303	Panel, front, white
43	131422100	Pad, leveling leg
43A	131422200	Pad, self lvlg leg, rear
44	5303309673	Screw, leveling leg, with pad
45	131346400	Pin, panel locator
45A	131346401	Pin, panel locator, front
46	134046600	Cabinet Assy, white, back and sides
47	131106701	Bracket, marriage, RH
47A	131091001	Bracket, marriage, LH
50 #	134101801	Lock, lid, w/ext switch
53	131452510	Panel, washer top, white
54	3204394	Dispenser, bleach
55	5303212876	Spring, lid assist
56	131243700	Screw, pan head, 8-18AB x 0.375

MOTOR/TUB

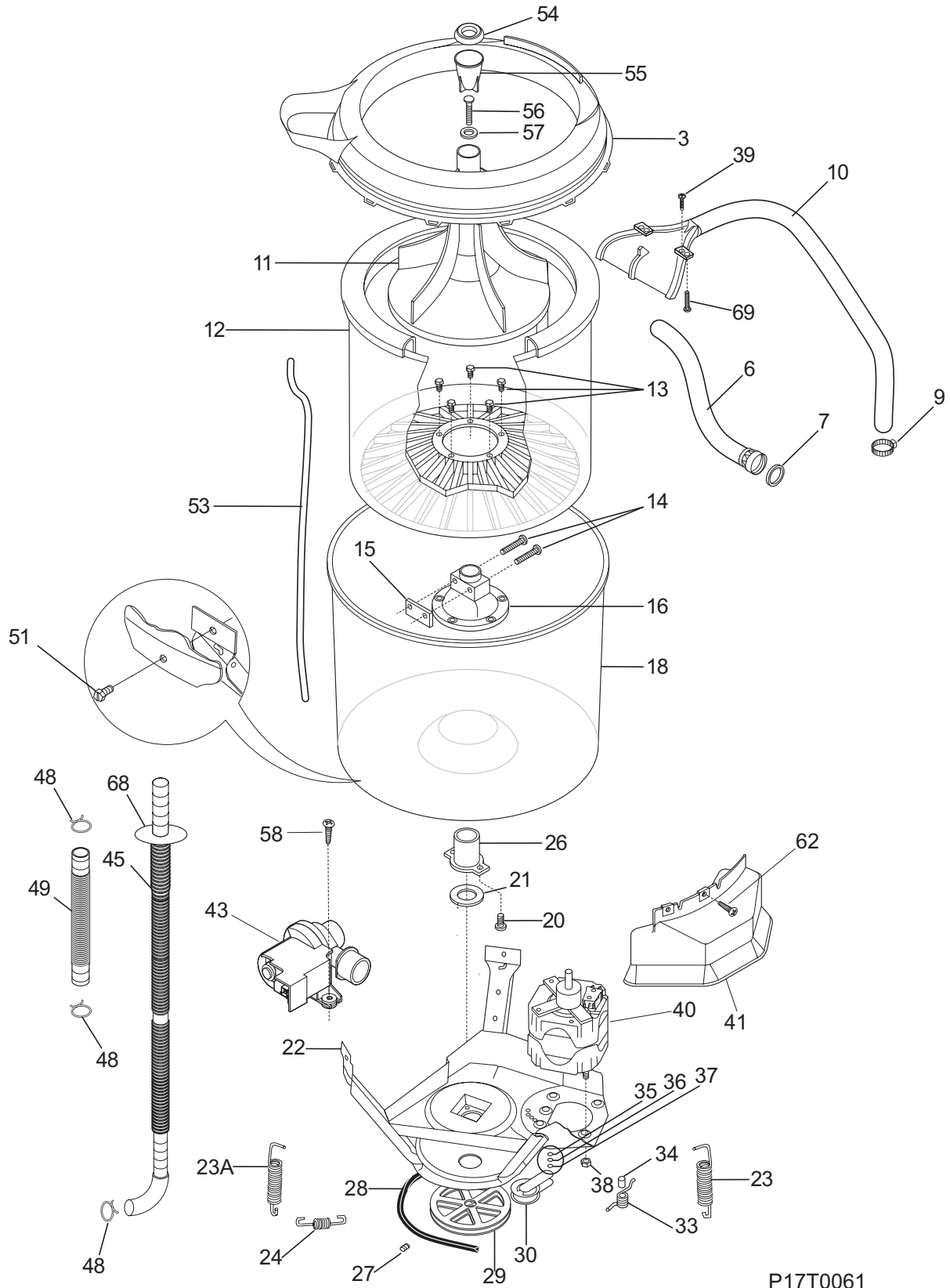

P17T0061

MOTOR/TUB

POS. NO	PART NO.	DESCRIPTION
3	131551102	Cover, splash tub, with seal
3*	131901400	• Seal, splash cover
6	5303272144	Hose, water inlet, metric/US cplg
7	5303161296	Washer, inlet hose
9	5303304824	Clamp
10	134211700	Hose Assy, w/nozzle
11	131427200	Agitator
12	131221300	Tub, spin
13	5303283293	Screw, trunion, 5/16-18 x 0.625, (5)
14	131192800	Screw, lockplate, 5/16-18 x 1.625
15	5308001923	Plate, lock
16	131545101	Trunnion
18	131557201	Tub, splash, w/air dome, brg
20	3205150	Screw, tub bearing, 8-12B x 0.750
21	5308002401	Washer, spin bearing, upper
22	131373610	Leg & Dome Assy
23	5303208858	Spring, vertical, short
23*	5303212877	Insert, spring adjuster, vertical
23A	5303208860	Spring, vertical
24	131373900	Spring, horizontal
26 #	3204405	Bearing, outer tub
27	5303304825	Screw, set, hex hd cup, 5/16-18 x 0.85, xmsn pulley, hex head cup pt
28 #	134511600	V-Belt, washer drive, standard 4L
29 #	131498301	Pulley, xmsn drive
30 #	131862900	Idler Arm Assy, VAW, with pulley
33	3204425	Spring, torsional
34	3204426	Sleeve, idler pivot
35	3161433	Ring, retaining
36	5303261031	Washer, pivot shaft
37	5303161306	Washer, spring type
38	5303318708	Nut, hex flange, motor mounting
39	131205100	Screw, #8 pan head, 10-10B x 0.500, cr/sq drive
40 #	134157100	Motor, 3/4 hp, 2 speed, with pulley
41	131513300	Shield, motor assy, w/speed nuts
43 #	134051300	Pump, drain, 50 Hz
45 #	134592700	Hose, drain
45*	131453000	Bushing, snap-in
45*	131663500	Cushion, drain hose, base
45*	134261300	Clip, drain hose, push-mount
45*	134745300	Clip, drain hose
48	131306234	Clamp, hose, wire
49 #	131494800	Hose, pump to tub
51	134164400	Screw, hex washer head, 5/16-18 x 0.625
53	5304401845	Tube, pressure, vinyl
54	131266800	Cap, dispenser
55	131206100	Cup, dispenser
56	131468900	Screw, agitator mtg, 5/16-18 x 1.250
57	131339600	Spacer, agitator mtg, rubber
58	134160900	Screw, washer hd, 10-16AB X 0.75
62	131258400	Screw, 10-16AB x 0.500
68	131707800	Ring, drain hose
68*	5303309503	Clip, drain hose, back sheet
69	131731500	Fastener, ratchet

TRANSMISSION

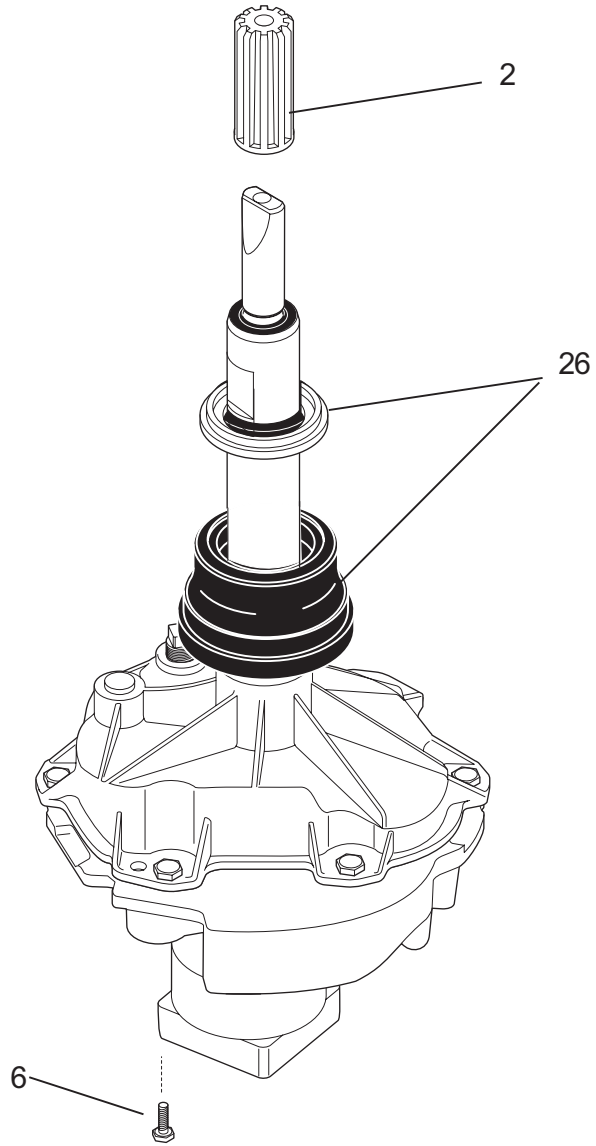
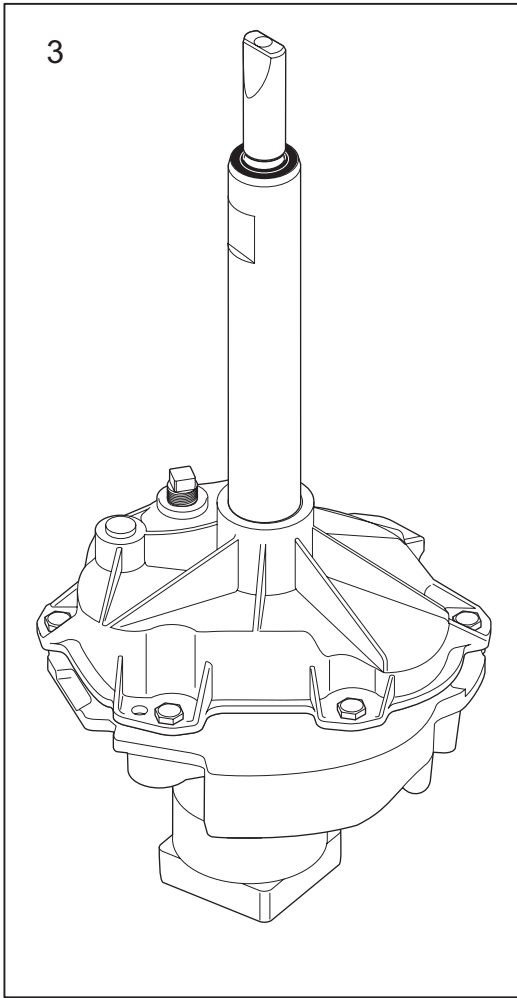

P17M0015

TRANSMISSION

POS. NO	PART NO.	DESCRIPTION
2 #	134418700	Hub, drive, agitator
3 #	134736400	Transmission, service kit
6	134197900	Screw, hex washer head, 1/4-20 x 0.437
26 #	5303279394	Seal Assy, tub, transmission

WIRING DIAGRAM

